



User manual of laser engraving

**MEGA PRO**

Dear customer,

Thank you for choosing **ANYCUBIC** products.

Maybe you are familiar with laser engraving technology or have purchased **ANYCUBIC** printers before, we still highly recommend that you read this manual carefully. The installation techniques and precautions in this manual can help you avoid any unnecessary damage or frustration.

More information please refer to :

1. <http://www.anycubic.com/>

**ANYCUBIC** website provides software, videos, models, after-sale service, etc.

Please go to our website to report any issues and we are likely to answer or solve all the questions for you!

2. Facebook page and Youtube channel as shown below.



**ANYCUBIC** website



Facebook page



Youtube channel

Team **ANYCUBIC**

# Technical Specification

## Laser engraving

Technology:	Laser engrave
File Format:	bmp
Engraving Size:	220×140 (mm <sup>2</sup> )
Picture Type:	bitmap
Pixel Size:	0.05-0.1 mm (suggested 0.1)
Laser Intensity:	1-100 (suggested 15 for kraft paper, 25 for wooden board)
Laser Height:	1-100 (suggested 50 for kraft paper, 52 for wooden board)
Picture Mirror:	Suggest to keep default value
Rated power:	1500mW
Supported Materials:	Wood, leather, paper, etc.



# Laser engraving diagram

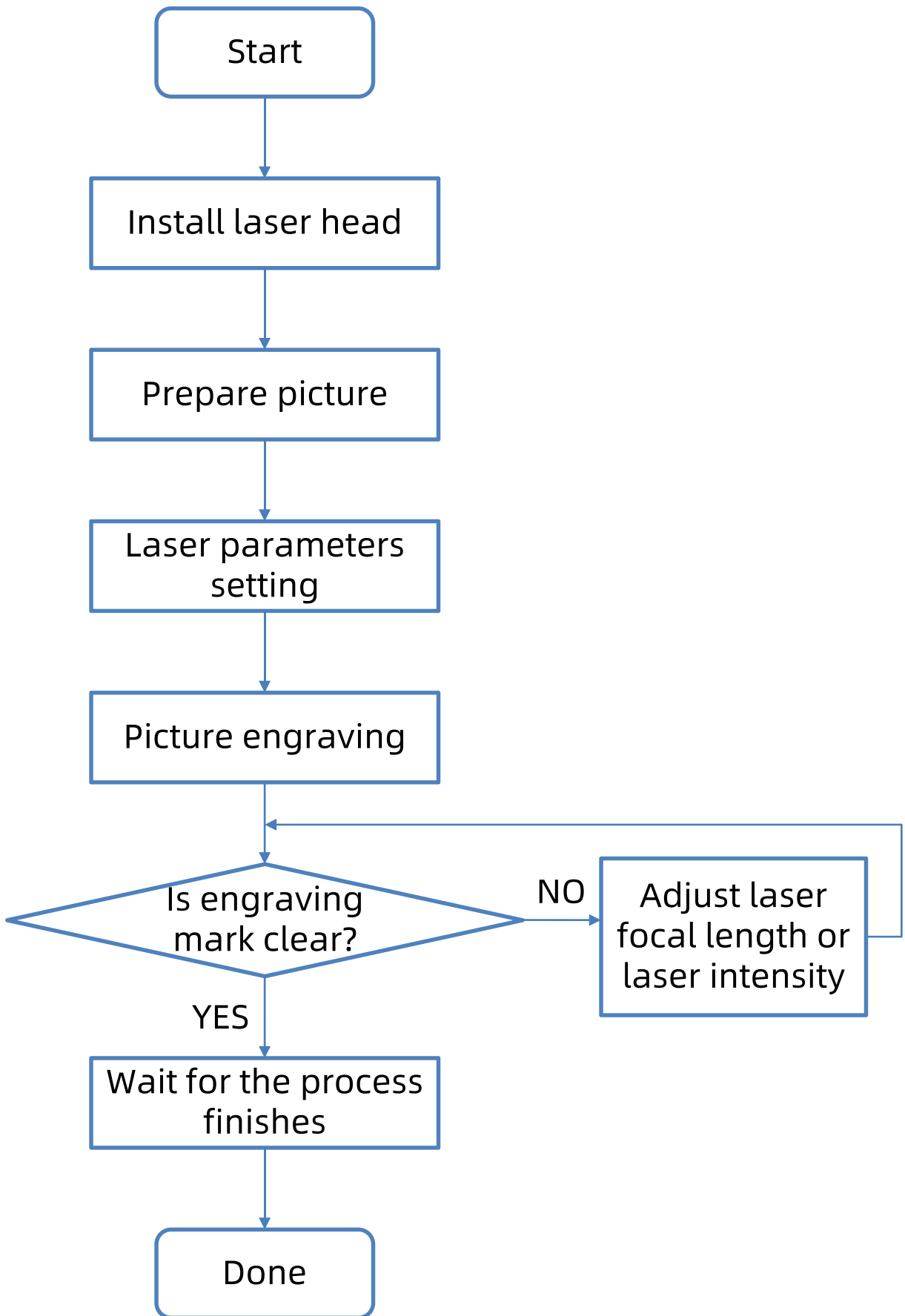

# Laser engraving

---

## Attention:

1. Laser engraving is designed to be used within ambient temperature ranging 15°C-50°C. Working outside this limit may result in low quality engraving.
2. Laser engraving supports materials such as wooden boards and kraft paper. Metal materials are not supported.
3. When switching working modes (3D printing mode and laser engraving mode), you must first power off the machine, then swap the corresponding cables on the green port.

# Laser engraving

## 1. Install laser head

(1) Power off the machine. Fix the laser head on the print head.

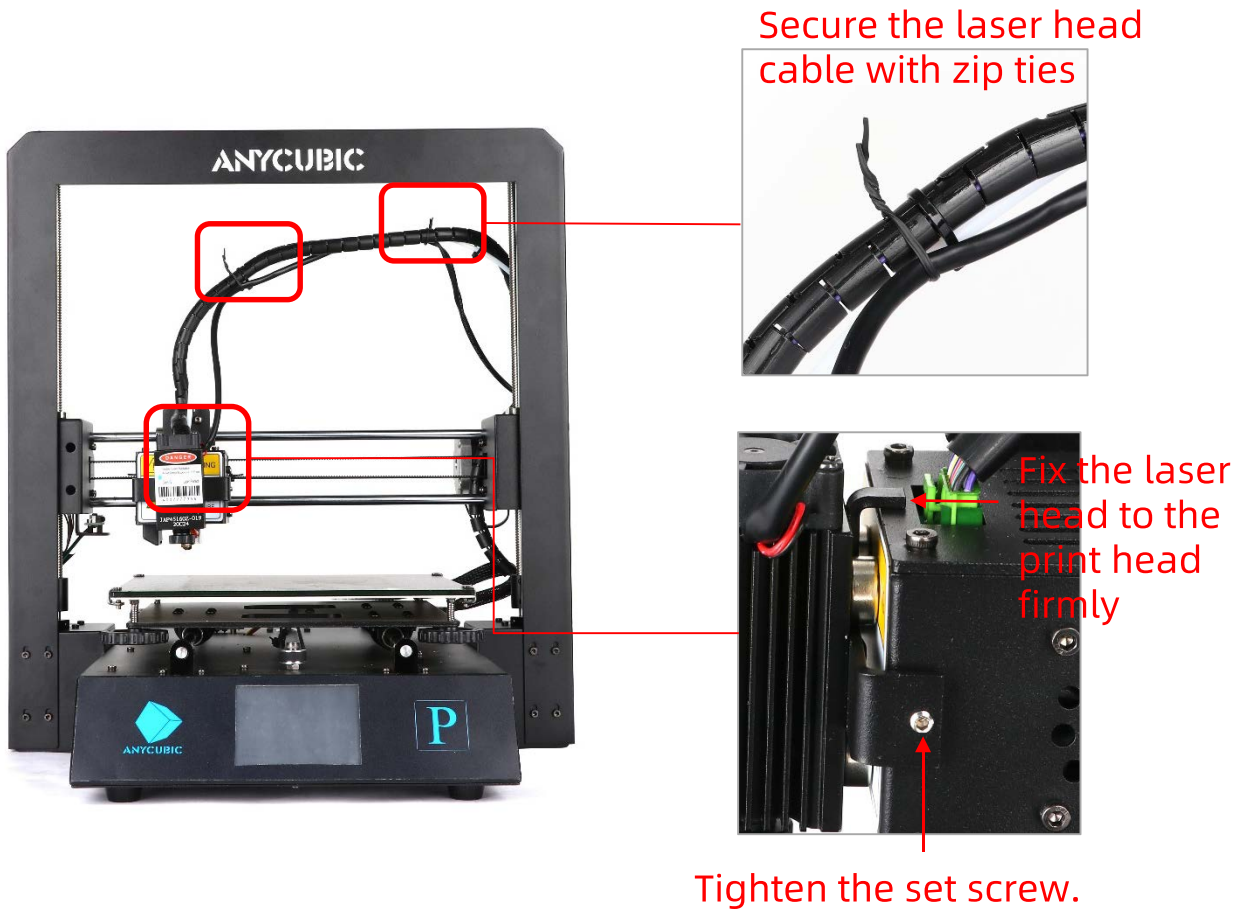

(2) Remove the green connector at the base. After that, connect the laser head's cable to this green port.

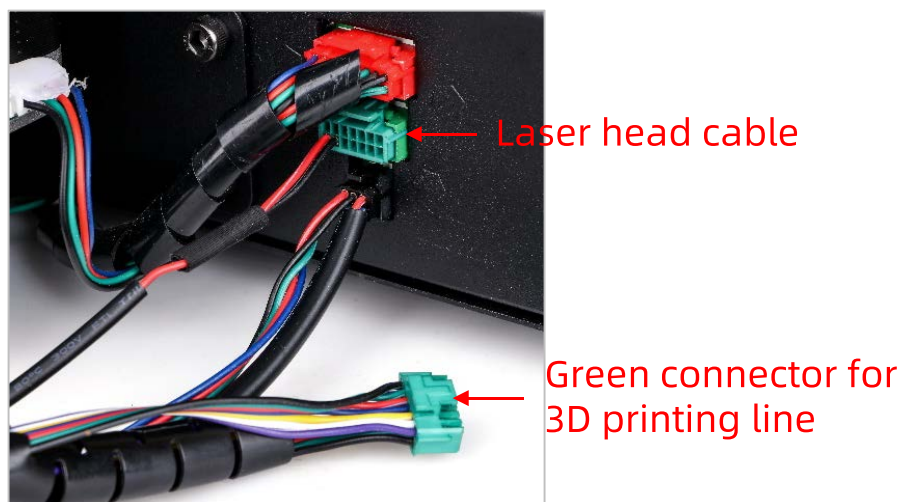

# Laser engraving

## 2. Prepare picture

The test file "landscape.bmp" which can be engraved directly has been preloaded to the memory card.

(1) Open the picture by a Image processing software (such as Paint, Photoshop, etc.).



(2) Set the picture pixels. (The picture pixel is  $\leq 2200 \times 1400$ )

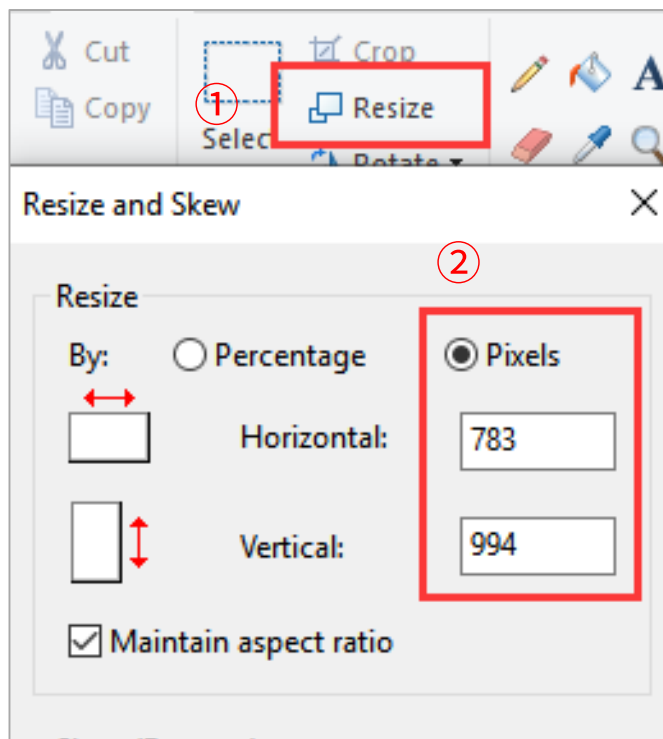

# Laser engraving

(3) Save the picture to memory card as “bmp” format.

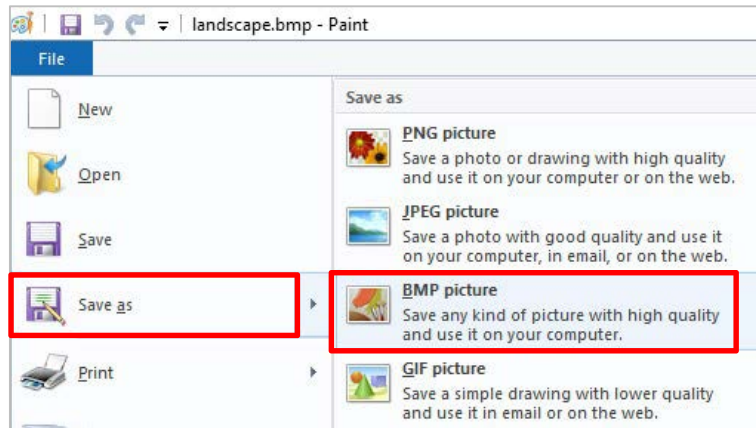

## 3. Laser parameters setting

(1) Choose the bmp file.

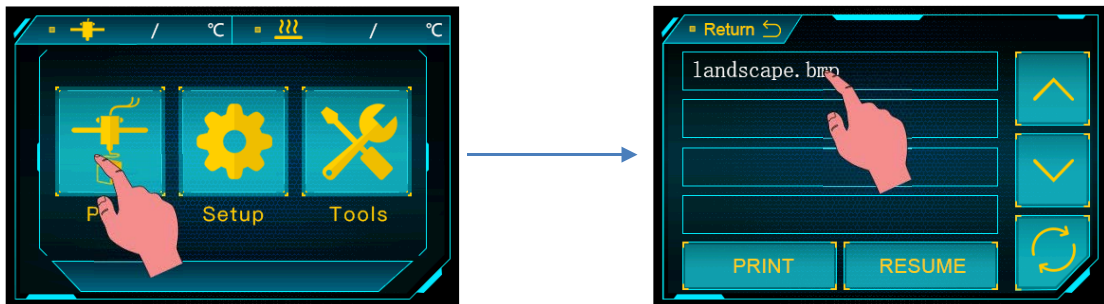

(2) Click the red box in the figure below to set the parameters.

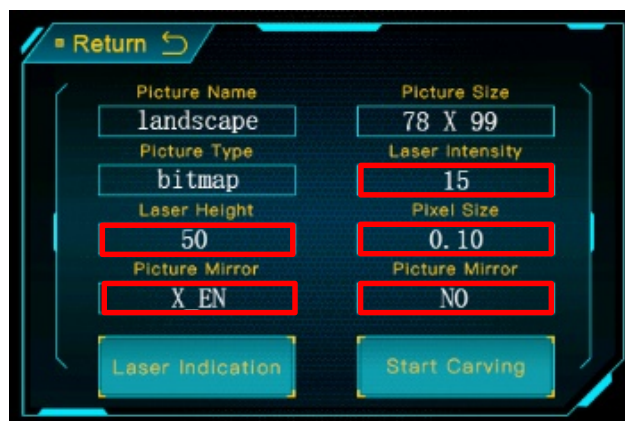



# Laser engraving

**Laser Intensity:** The larger the laser intensity value, the darker the grayscale part of the picture. It is recommended to set 15 for kraft paper and 25 for wooden board.

**Laser Height:** The distance between laser head and printing platform. It is recommended to set 50 for kraft paper and 52 for wooden board.

**Pixel Size:** The size of each pixel of the picture. The recommended setting is 0.1.

**Picture Mirror:** "NO" and "X\_EN"

"X\_EN": The picture will be mirrored in X direction.

**Picture Mirror:** "NO" and "Y\_EN"

"Y\_EN": The picture will be mirrored in Y direction.

## 4. Picture engraving

(1) **Wear protective glasses.** Place a kraft paper on the platform, then click "Laser Indication", the laser head would travel square to show the working area. You may need to adjust the position of the kraft paper to place it inside the working area. Then tape the kraft paper to the platform.

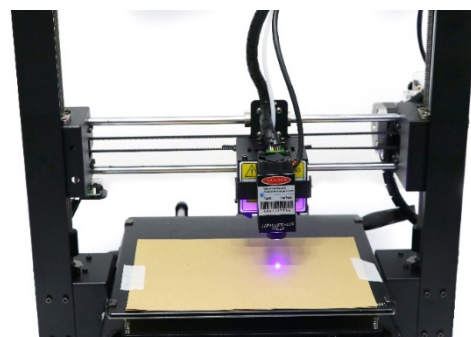

# Laser engraving

(2) Click "Start Carving".

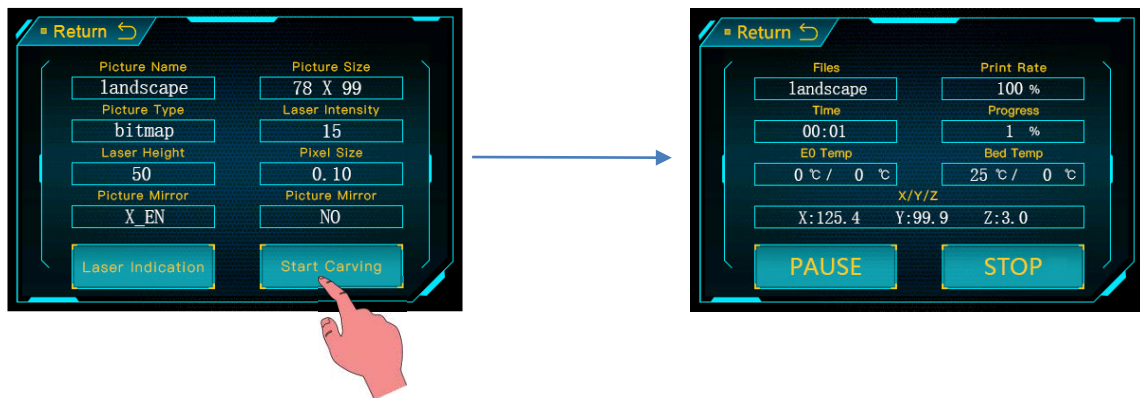

**Q:** Print head does not move after clicking "Laser Indication" or "Start Carving".

**A:** The machine needs time to process the picture. If there are blank area around the picture, the machine may spend more time to process the blank area before actually start from the first gray pixel. The blank space around the picture should be minimized to reduce the time it takes before start.

## 5. The laser engraving marks on engraving materials are not clear

If the mark of laser engraving on the material is not clear, first adjust the laser focal length. If the engraving mark is still not clear, you need to adjust the laser intensity.

(1) Adjustment of the laser focal length

**Adjust the laser focal length during the engraving process. Wear protective glasses,** and carefully turn the laser head nut to visually find the minimum light spot.

# Laser engraving

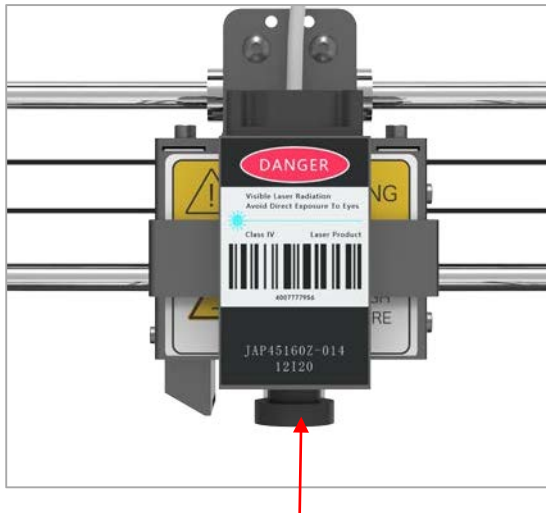

Laser head nut

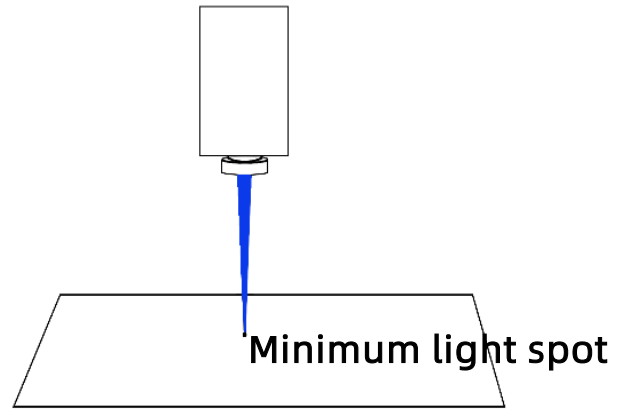

(2) Adjustment of the laser intensity

Adjust the laser intensity during the engraving process.

Click the screen to return to the main menu, and then click "Setup" → "Laser" → "Laser Intensity". (Increase laser intensity with an interval of 2)

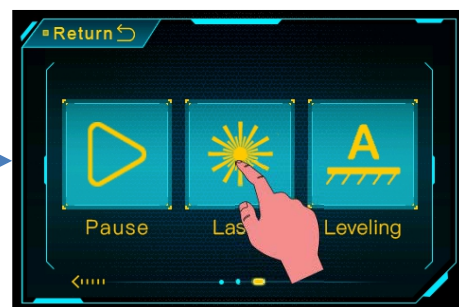
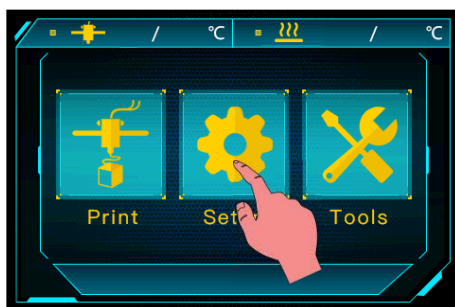

## Laser engraving

---

Thank you for purchasing **ANYCUBIC** products! Under normal usage and service, the products have a warranty period up to one year. Please visit **ANYCUBIC** official website([www.anycubic.com](http://www.anycubic.com)) to report any issues with **ANYCUBIC** products. Our professional after-sale service team would response within 24 hours and solve the issue.