

AlGaAs Infrared Laser Diode

ADL-80V01NL

DATE : 2006/12/27 Ver 2.0

★808nm 500mW 9 φ TO-Type

High Power Laser Diode

• Features

1. Low operation current
2. Cost effective

• Applications

1. Pumps for solid state lasers
2. Medical use

• Absolute maximum ratings

Parameter	Symbol	Condition	Rating	Unit
Light output power	P_O	CW	500	mW
Reverse voltage (LD)	V_{RL}	-	2	V
Reverse voltage (PD)	V_{RD}	-	30	V
Forward current (PD)	I_{FD}	-	10	mA
Case temperature	T_C	-	-10~+50	°C
Storage temperature	T_S	-	-40~+85	°C

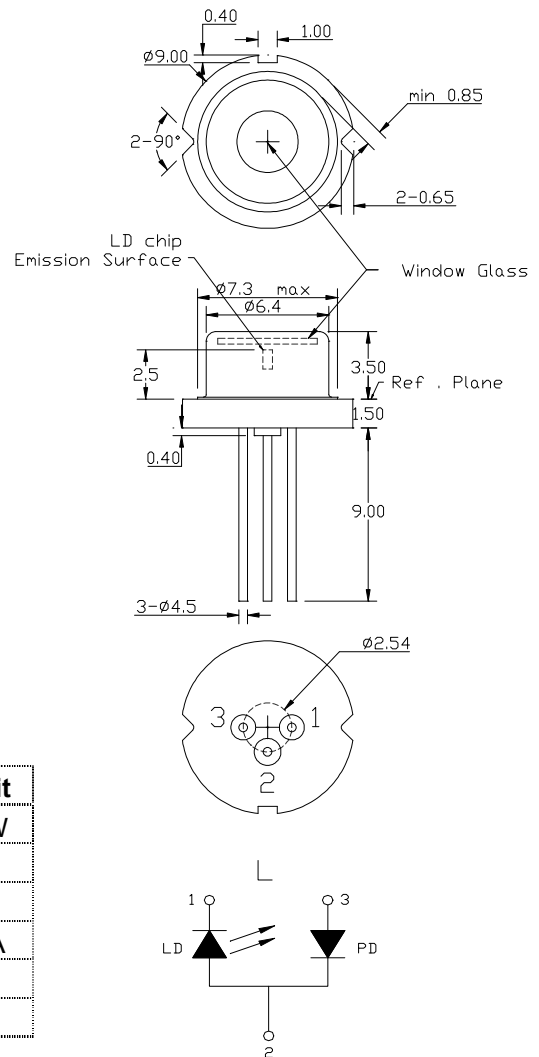

• Electrical and optical characteristics ($T_c=25^\circ\text{C}$)

Parameter	Symbol	Min.	Typ.	Max.	Unit	Conditions
Peak wavelength	λ	805	808	811	nm	$P_o=500\text{mW}$
Threshold current	I_{th}	-	150	200	mA	
Operating current	I_{op}	-	600	700	mA	$P_o=500\text{mW}$
Operating voltage	V_{op}	-	1.8	2	V	$P_o=500\text{mW}$
Differential efficiency	η	0.8	1.0	-	mW/mA	$P_o=400\text{-}500\text{mW}$
Monitor current	I_m	0.15	0.8	1.20	mA	$P_o=500\text{mW}$, $V_{RD}=0\text{V}$
Parallel divergence angle	$\theta_{ }$	-	10	15	degree	
Perpendicular divergence angle	θ_{\perp}	-	44	48	degree	$P_o=500\text{mW}$
Emission point accuracy	$\Delta x \Delta y \Delta z$	-80		+80	um	

• Precautions

- * Do not operate the device above maximum ratings. Doing so may cause unexpected and permanent damage to the device.
- * Take precautions to avoid electrostatic discharge and/or momentary power spikes. A change in the characteristics of the laser or premature failure may result.
- * Proper heat sinking of the device assures stability and lifetime. Always ensure that maximum operating temperatures are not exceeded.
- * Observing visible or invisible laser beams with the human eye directly, or indirectly, can cause permanent damage. Use a camera to observe the laser.
- * No laser device should be used in any application or situation where life or property is at risk in event of device failure.
- * Specifications are subject to change without notice. Ensure that you have the latest specification by contacting us prior to purchase or use of the product.

AlGaAs Infrared Laser Diode

ADL-80V01NL

DATE : 2006/12/27 Ver 2.0

