

808nm High Power C-mount Laser Diode

Model: AL0808FXXC-09XX

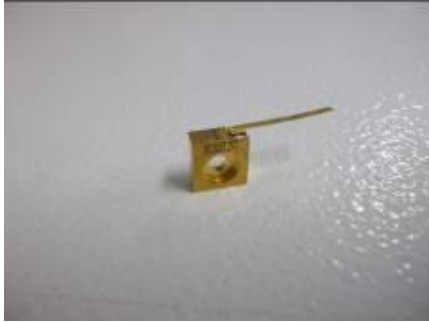

Features:

- Output power: 1000/2000/3000/5000mW
- Efficient quantum well structure
- Center Wavelength: 808nm
- Package: C-mount

Absolute Maximum Ratings($T=25\text{ }^{\circ}\text{C}$)

Parameter	Symbol	Unit	Min	Max	Note
Reverse Voltage	V_r	V	-	2	-
Operating Temperature	T_{op}	$^{\circ}\text{C}$	10	30	
Storage Temperature	T_{stg}	$^{\circ}\text{C}$	10	85	
Solder Temperature	S_{temp}	$^{\circ}\text{C}$	-	260	10 seconds max

Electro-Optical Characteristics($T=25\text{ }^{\circ}\text{C}$)

Symbol	Parameter	Unit	AL0808F1000	AL0808F2000	AL0808F3000	AL0808F5000
P_o	Optical output power	mW	1000	2000	3000	5000
Δc	Center wavelength	nm	808 \pm 5	808 \pm 5	808 \pm 5	808 \pm 5
$\Delta\lambda$	Spectral width	nm	\leq 3.5	\leq 5	\leq 5	\leq 5
I_{th}	Threshold current	mA	\leq 300	\leq 500	\leq 700	\leq 1000
I_{op}	Operating current	mA	\leq 1300	\leq 2500	\leq 3700	\leq 6000
V_f	Operating voltage	V	1.6~2.2	1.8~2.4	1.8~2.4	1.8~2.4
η	Slope Efficiency	W/A	\geq 1	\geq 1	\geq 1	\geq 1
$\theta_{//} \times \theta_{\perp}$	Beam divergence	o/ o	12/40	12/40	12/40	12/40
$\theta_{//} \times \theta_{\perp}$	Beam divergence (fast axis collimated)	o/ o	12/10	12/10	12/10	12/10
	Wavelength temperature coefficient	nm/ $^{\circ}\text{C}$	\leq 0.3	\leq 0.3	\leq 0.3	\leq 0.3
	Emitting area	μm	50/100 \times 1	100/150 \times 1	200 \times 1	200 \times 1
	Polarization		TE	TE	TM	TM

Outline Drawings (in: mm)

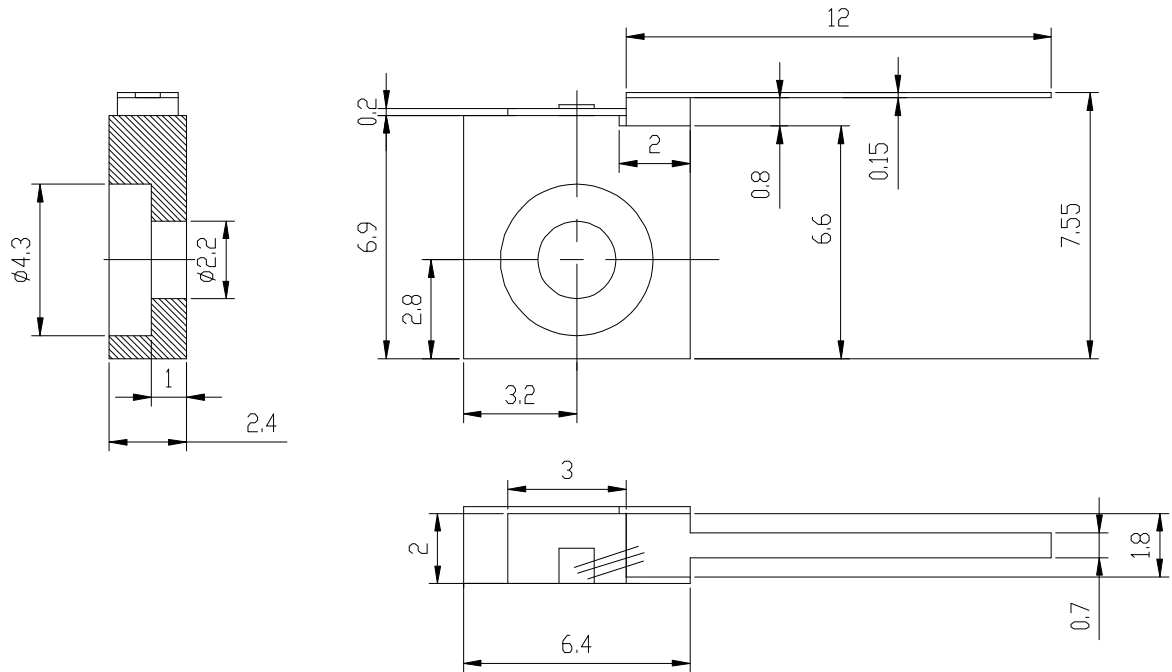

Pin Assignment:

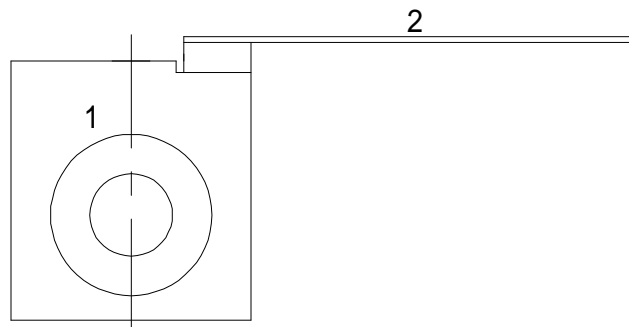

Type \ Pin	1	2
09	LD Anode	LD Cathode

Ordering information:

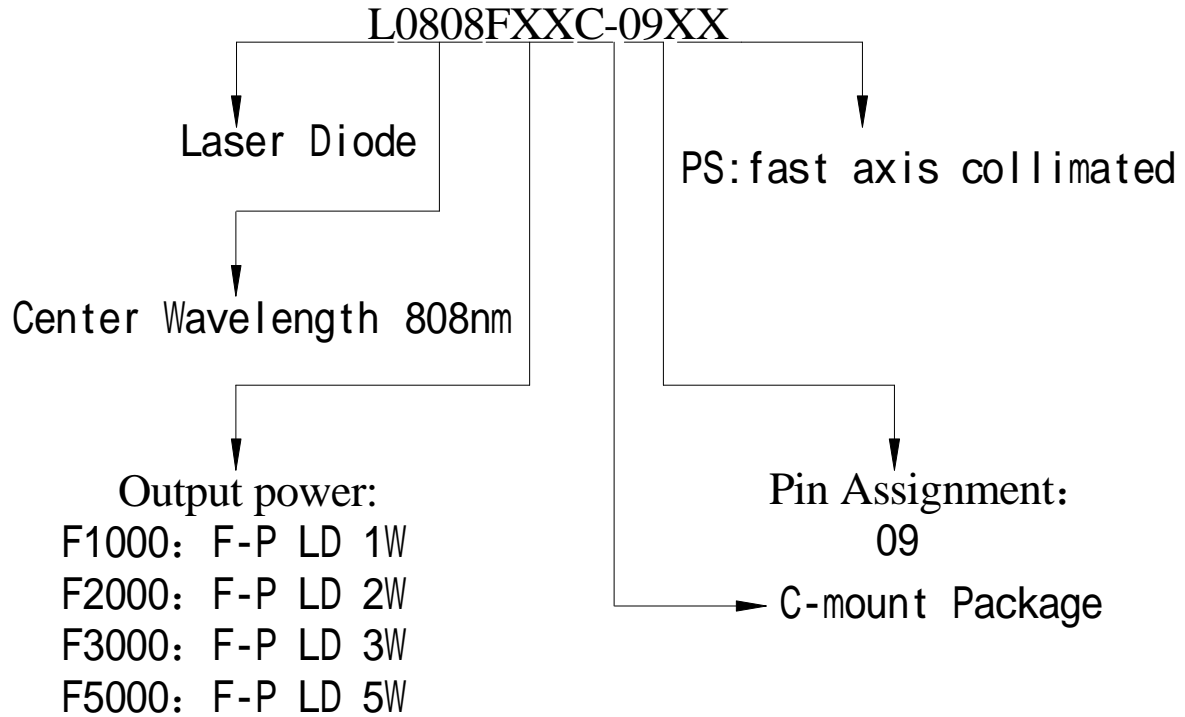

Precaution:

- (1) The laser diodes should be handled in the same manner as ordinary semiconductor device to prevent the electro-static damages. For safety keeping and carrying, the modules should be packaged with ESD proof material. For assembling, the workbench, the soldering iron and the human body should be grounded.
- (2) Please pay special attention to the atmosphere condition because the dew on the module may cause some damages.
- (3) Under such a strong vibration environment as in automobile, the performance and reliability are not guaranteed.
- (4) A voltage stabilizer should be taken into consideration for the power supply, and shock voltage should be avoided during the process of switching on and off of the supply in order to prevent the device from damaging.
- (5) Pay attention to the dust polluting. The device may be damaged when operating in atmosphere because the dust may be absorbed onto the region of lighting under the action of electric field.

Warning: Direct exposure of one's eyes to the laser beam or long time exposure of one's skin to the beam must be avoided.